

FUNKTION-ONE

XO-1 USERS MANUAL

FUNKTION-ONE

XOI Quick Reference

Accessing channels: Use channel's SELECT button.

First press accesses that channel's gain.

Second press accesses last viewed parameter.

Third press will drop back to the default screen.

To scroll through a channel's parameters, use the **BACK** and **NEXT** keys.

Accessing menus: Press the **MENU** key, then the **BACK** and **NEXT** keys to find the sub-menu required, and select using the **ENTER** key. This applies to all levels of menu; **ENTER** always confirms selections.

The Menus and their Contents

Input Setup Sub-menu: Used for ganging input gain and base delays.

X-over Sub-menu: Used for storage and recall of crossovers, including format, output EQ, output delay, output gain, and limiter settings. Also used for design of new crossovers.

Security Sub-menu: Used for locking various features of the units, using a four digit code.

System Sub-menu: Used to view the units status, and select various global options such as parametric EQ 'Q' or bandwidth units, and output meter monitoring point (pre or post mute).

Notes

The crossover and output settings are stored and recalled independently (using store/recall a X-Over) from the input settings (using store/recall input memory).

The output meters show level, in dB, from the limiter threshold. The input meters show level, in dB, from input clip.

The high and low-pass filters are defined independently on each channel.

To access the limiter attack and release parameters, select "Auto Limiter TC: No" when designing a crossover.

To swap parametric filter units between bandwidth ('BW') and 'Q', enter the 'System sub-menu, select 'Filter Q or BW', and select required readout units.

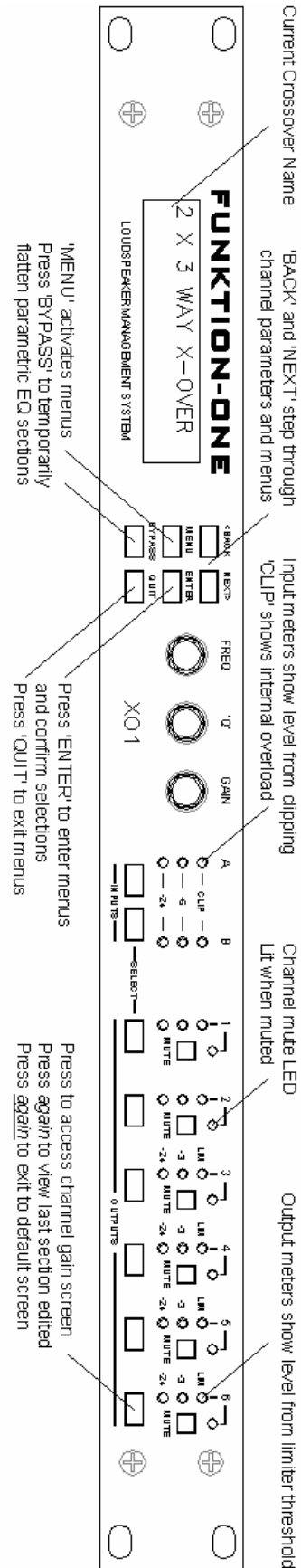

Contents

XOI Quick Reference	1
The Menus and their Contents	1
Notes	1
Contents	2
Important Safety Information	4
Thanks	5
Unpacking the XOI	5
Introduction	6
Features	6
Front Panel Familiarisation	8
Rear Panel Connections	9
Operating the XOI	10
Preliminary Set-up	10
XOI Configurations	11
Introduction	11
2 x 2 way with Mono Sum	11
2 x 3 way	12
4 way + 2	13
5 way + 1	14
6 way	15
Screen Layouts Overview	16
Gain Screen	17
Polarity Screen	18
Delay Screen	19
High and Low Pass Filter Screens	20
Parametric Equaliser Screen	21
Limiter Screen	22
Menu Selection	23
Input Setup Sub-menu	24
Gang Inputs	24
X-over Sub-Menu	25
Load a Xover	25
Design a Xover	25
Store a Xover	25
Erase a Xover Mem	25
Security Sub-Menu	26
User Specific	26
Xover Only	26
Xover + Trim	26
Xover + Trim + Mute	26
Changes Only	26
Changes + View	26
Changes + Mutes	26
EVERYTHING	26
Entering the Password to Complete the Locking Operation	27

System Sub-Menu	28
System Status	28
LCD Contrast	28
LED Brightness	28
Temperature Alarm	28
Wake-up Time	28
Output Meters	28
Filter Q or BW	28
Delay Time/Distance	28
Interface Sub-Menu	29
Interface Setup	29
AES / EBU Sub-Menu	30
Routing Options	30
AES Diagnostics	30
AES / EBU Connections	30
Operating Notes	31
Operating Level	31
Grounding	31
Crossover Filter Slopes	32
Time Alignment	32
Output Limiters	33
Setting Accurate Limiter Thresholds	34
Specifications	36
Warranty	37
Options and Accessories	37
Appendices	38
Appendix 1: Limiter threshold in dB to Vrms lookup table.	38
Appendix 2: Default X-over settings and names for all formats.	39
Appendix 3: Equalisation Curves	40



An example of this equipment has been tested and found to comply with the following European and international Standards for Electromagnetic Compatibility and Electrical Safety:

Radiated Emissions (EU): EN55013-1 (1996)

RF Immunity (EU): EN55103-2 (1996) RF Immunity, ESD, Burst Transient, Surge, Dips & Dwells

Electrical Safety (EU): EN60065 (1993)

Important Safety Information

Do not remove Covers.

No user serviceable parts inside, refer servicing to qualified service personnel.

This equipment must be earthed.



**CAUTION
RISK OF ELECTRIC SHOCK
DO NOT OPEN
DO NOT EXPOSE TO RAIN OR MOISTURE**



**ATTENTION
RISQUE DE CHOC ELECTRIQUE
NE PAS ENLEVER
NE PAS EXPOSER A LA PLUIE NI A L'HUMITE**



It should not be necessary to remove any protective earth or signal cable shield connections. Do not defeat the purpose of the polarized or grounding-type plug. A polarized plug has two blades with one wider than the other. A grounding type plug has two blades and a third grounding prong. The wider blade and the third prong are provided for your safety. When the provided plug does not fit into your outlet, consult an electrician for replacement of the obsolete outlet.

Only use this equipment with an appropriate mains cord.

In the USA the cord should comply with the requirements contained in the Standard for Cord Sets and Power Supply Cords, UL 817, be marked VW-1, and have an ampacity rating not less than the marked rating of the apparatus.

Thanks

Thank you for choosing the XO1 for your application. Please spend a little time reading through this manual, so that you obtain the best possible performance from the unit.

All our products are carefully designed and engineered for cutting-edge performance and world-class reliability. If you would like further information about this or any other product, please contact us.

We look forward to hearing from you in the near future.

FUNKTION-ONE

Unpacking the XO1

After unpacking the unit, please check it carefully for any damage. If any is found, immediately notify the carrier concerned - you, the consignee, must instigate any claim. Please retain all packaging in case of future re-shipment.

Introduction

The XO1 is a powerful DSP based audio processor, ideally suited for live sound applications, where it combines the functions of a multitude of conventional products in a compact 1U unit. To achieve this, the XO1 has two inputs and six outputs which can be configured in five basic crossover modes – 3 x 2 way; 2 x 3 way; 4 way; 5 way; and 6 way.

Each input has a gain control, and variable base delay. Each output has a gain control, variable delay, high and low pass filters, five bands of fully parametric equalisation, polarity switching and, additionally, a fully featured limiter.

Multi-part security lock-out is available for all controls.

The XO1 is also available with optional AES/EBU digital inputs and outputs. It has been designed for quick, intuitive adjustment through the use of multiple controls to provide an easy-to-use interface.

Features

Superb audio quality – carefully optimised double precision signal processing coupled with a 40-bit internal data path ensures a dynamic range in excess of 110dB. The high sampling rate means minimal filtering providing exceptional sonic purity.

A flexible 2-input/6-output multi-mode format caters for any crossover configuration, regardless of scale.

A total of 30 parametric equalisation bands are available, each providing +15 to – 30dB of gain at centre frequencies between 20Hz and 20kHz, with a wide range of 'Q's available between 0.4 to 128. All parameters feature fine resolution with 1/36 octave frequency steps, 0.1dB gain increments, and 100 'Q' settings. Any parametric section can also be set to operate as a high or low shelving filter.

Each output features a high performance limiter, provided with complete control over attack, release and threshold parameters. To aid set-up, the output meters show headroom to the limiter threshold, and use time constants that track those of the limiter to display precise power usage.

Each output features variable high and low pass filters, with a choice of 12, 18 or 24dB/Octave roll-off, and Butterworth, Bessel or Linkwitz-Riley responses. Independent control of each high and low pass filter allows asymmetric crossover bands to be created.

Delay of up to 650mS may be independently set for each output, with an exceptionally fine minimum increment of 2.6 μ S.

Three velocity-sensitive encoders provide a familiar and intuitive control format with all filter information displayed simultaneously on a backlit LCD screen.

AES/EBU Digital input and output interfaces are available as an option.

Input and output balancing transformers are also available as an option.

Front Panel Familiarisation



LCD Screen : shows menu options, channel information, and various parameters as they are adjusted.

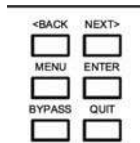

Next Key : moves forwards through the list of available parameters.

Back Key : moves back through the list of available parameters.

Menu Key : activates the main menu. A second press selects the last menu edited. Selection of different menus may be accomplished using the Back and Next keys, or by turning the 'Freq' encoder.

Enter Key : enters the chosen menu and confirms choices.

Bypass Key : bypasses the currently selected parametric EQ section. Note that, for safety reasons, the high and low pass filters cannot be bypassed using this key.

Quit Key : exits the menu.

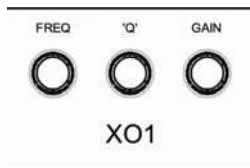

Encoders : three velocity sensitive controls allow the relative parameter displayed on the LCD screen to be adjusted.

PC Card : PCMCIA card slot allows back-up of input memory sets, unit cloning data and facilitates the download of software updates.

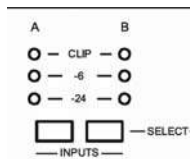

SELECT Keys : one for each input and output, allowing instant access to the gain screen for the selected channel. The accompanying LED illuminates whilst editing is active.

Input Meters : display available headroom below clipping. The yellow '-6dB' LED illuminates at 6dB below the actual clipping point of the input section. The red 'Clip' LED shows digital overflow and can therefore illuminate independently of the rest of the meter.

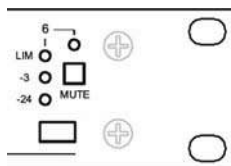

Output Meters: display headroom below limiting. The yellow LED illuminates 3dB below limiting for that channel. The red LED indicates the onset of limiting.

Mute Keys: mutes the appropriate channel, and illuminates the associated LED.

Rear Panel Connections

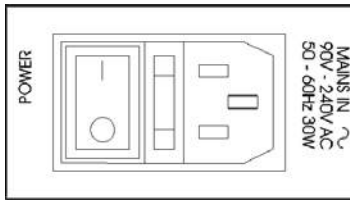

Power Switch: turns the units mains supply off and on.

Mains Fuse: located in a finger-proof holder adjacent to the mains inlet. A spare fuse is also located in this holder.

Mains Inlet: connected via a standard IEC socket.

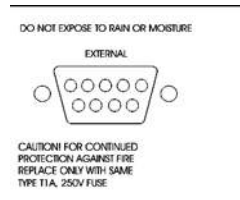

External: RS232 standard via a 9 pin D-type connector, for connection to a PC, enabling the uploading of new software to the unit.

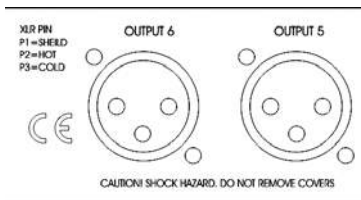

Audio In-Out: 3 pin XLR sockets are provided for each channel. All are fully balanced, pin 2 hot, 3 cold, 1 screen.



Always replace the fuse with the correct type and rating as shown on the rear panel legend.

Operating the XO1

Preliminary Set-up

The procedure below should be followed when first installing a XO1.

Design your crossover! To do this, press MENU, and use the BACK or NEXT key to select 'X-over sub-menu' and then press ENTER. Use the BACK or NEXT key to select 'Design a X-over' and then press ENTER. Finally, use the BACK or NEXT key to select the desired configuration and follow the set-up wizard to finalise your design.

Note that when in a menu, ENTER is always used to confirm selections. The current selection is marked with an asterisk '*'.

Use the SELECT keys on each output channel with the BACK and NEXT keys to select the high pass filters, low pass filters, parametrics etc. Note that when designing a new crossover, the high and low pass filters will be set to default values. See appendix 2 for more information.

Use the SELECT keys on each input channel with the BACK and NEXT keys to select the gain, delay and parametrics available on each input.



Note that if no action is taken in menu mode, the unit will return to normal 'default' mode after about twenty (20) seconds. Repeat the above directions to return to menu mode.

XOI Configurations

Introduction

To simplify the set-up of the XOI, 5 crossover modes are selectable from the X-over sub-menu. These all have parametric equalisers, high and low pass filters, gain controls, delay and limiters. The following set of diagrams detail how each of the five modes is internally configured. Note that the 2 x 3 way and 3 x 2 way modes also offer the option of ganged parameter adjustment for stereo systems.

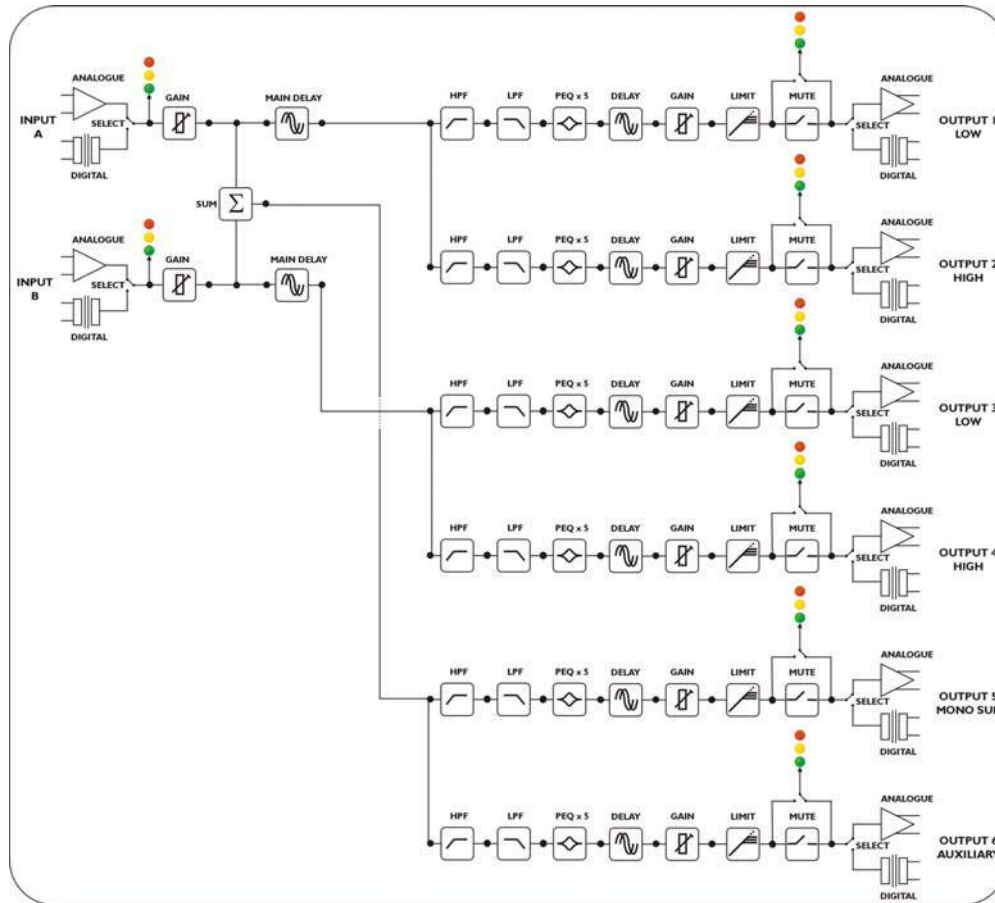

2 x 2 way with Mono Sum

This format feeds input A to outputs 1 and 2, designated low and high respectively. Input B feeds outputs 3 and 4, low and high respectively. Outputs 5 and 6 are both fed from the sum of inputs A and B. Output 6 is a full bandwidth output by default, with output 5 being bandwidth limited as a sub output.

2 x 3 way

This format feeds input A to outputs 1, 2, and 3 designated low, mid, and high respectively. Input B feeds outputs 4, 5, and 6, as low, mid, and high respectively. Note that this configuration, as with the 2 x 2 way, can have the outputs ganged for stereo operation. This gangs outputs 1 & 4, 2 & 5, and 3 & 6, so that they track identically. It can be selected or modified by entering the 'Design a Xover' function again.

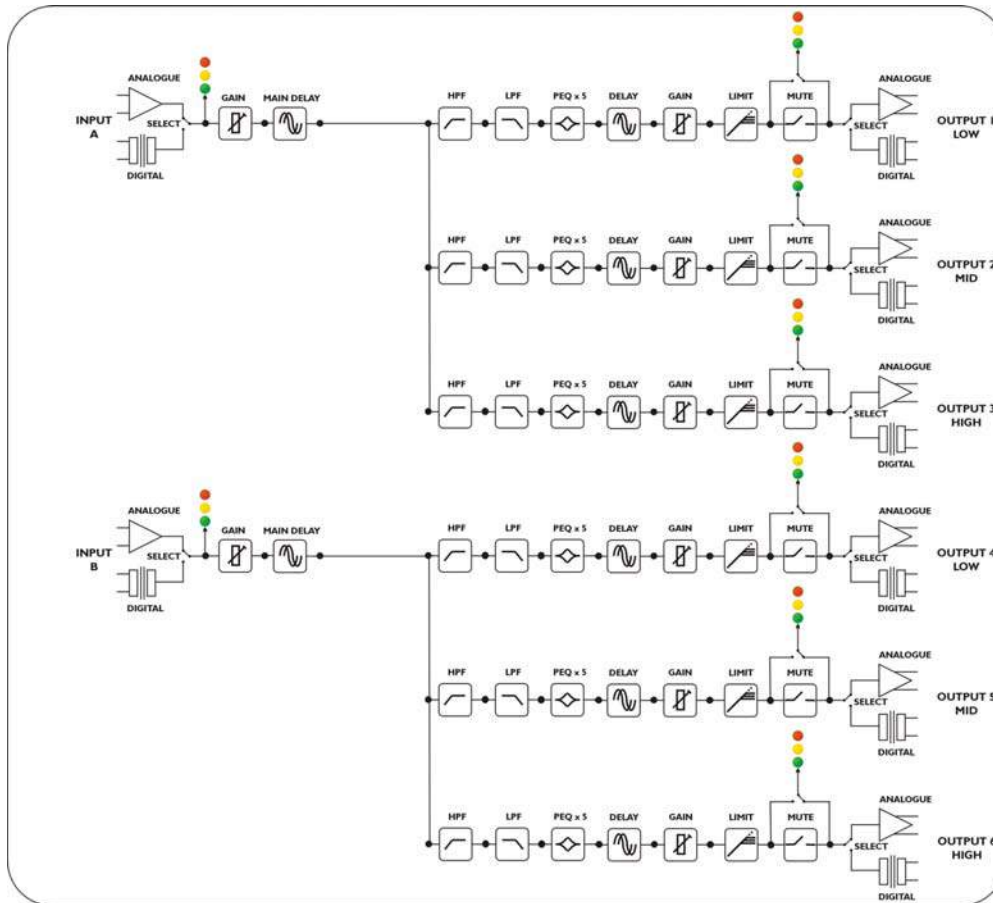

4 way + 2

This format feeds input A to outputs 1, 2, 3, and 4 designated low, lo-mid, hi-mid and high respectively. Outputs 5 and 6 are configured as auxiliaries, with their source being either input B, or the sum or inputs A and B.

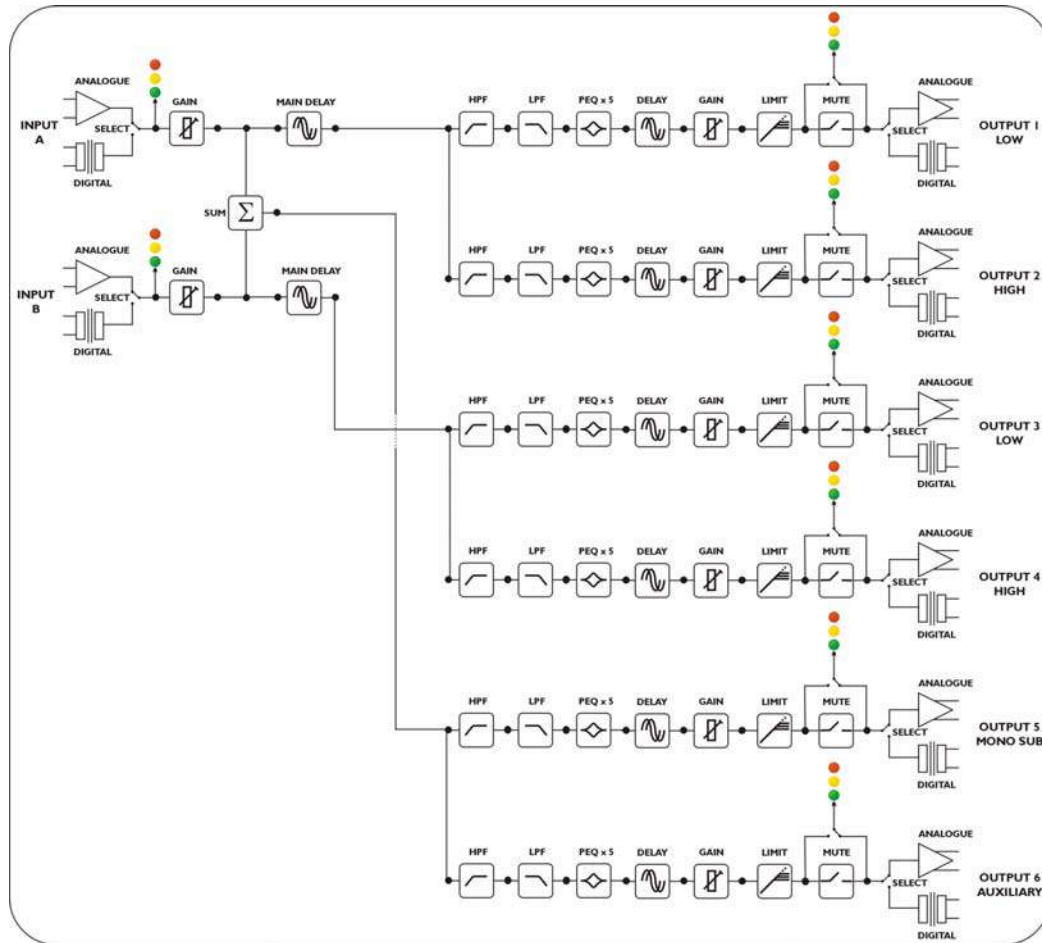

5 way + 1

This format feeds input A to outputs 1, 2, 3, 4, and 5 designated sub, low, lo-mid, hi-mid and high respectively. Output 6 is configured as an auxiliary, with the source being either input B, or the sum or inputs A and B.

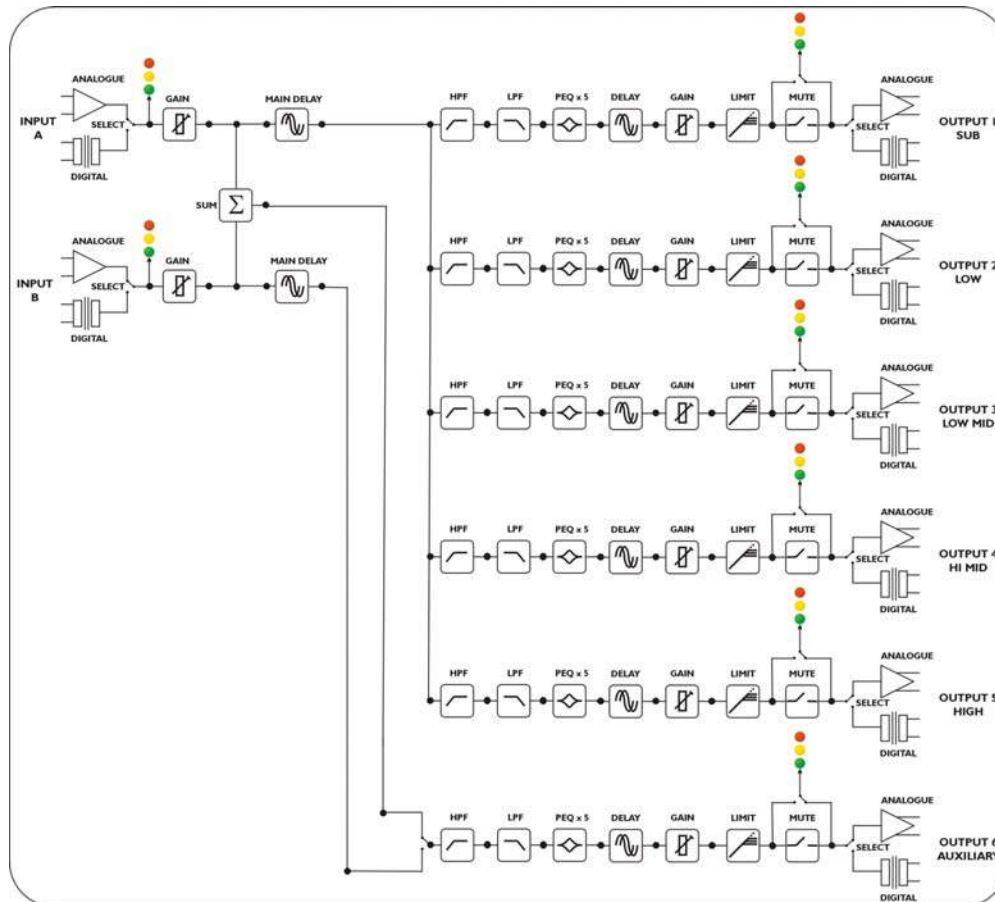

6 way

This format feeds input A to all outputs designated lo-sub, through high, 1 to 6 respectively.

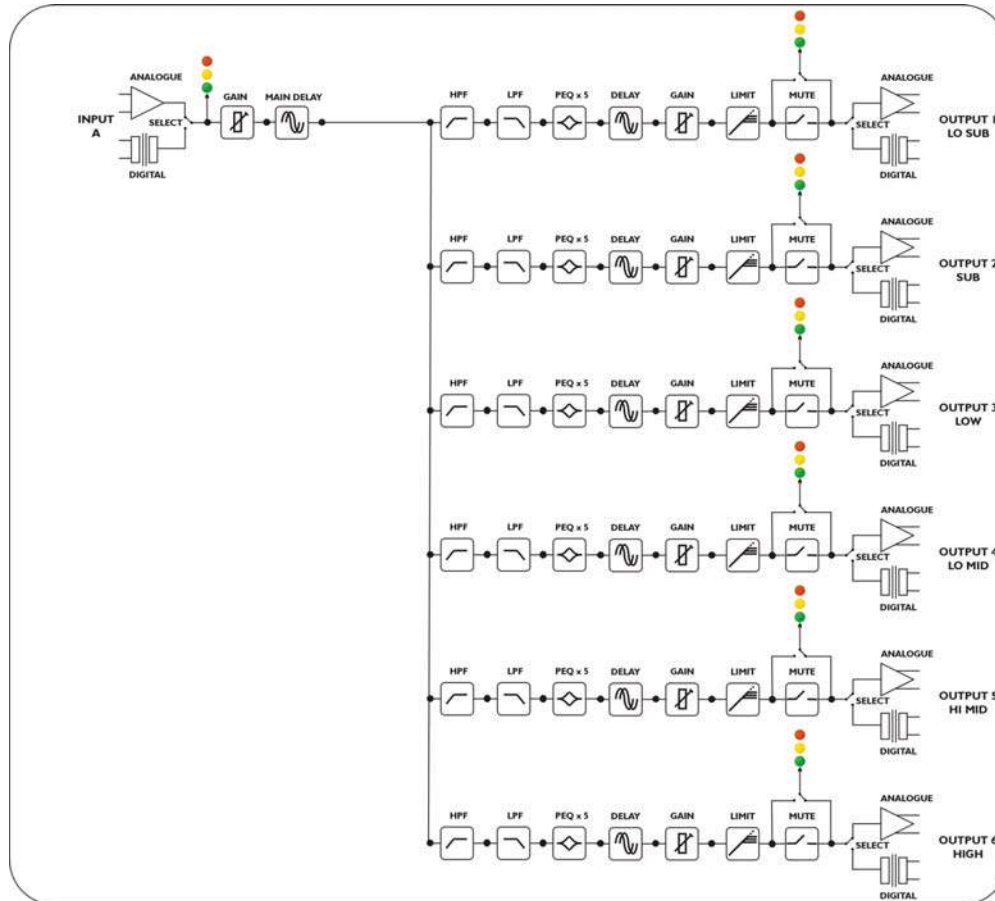

Screen Layouts Overview

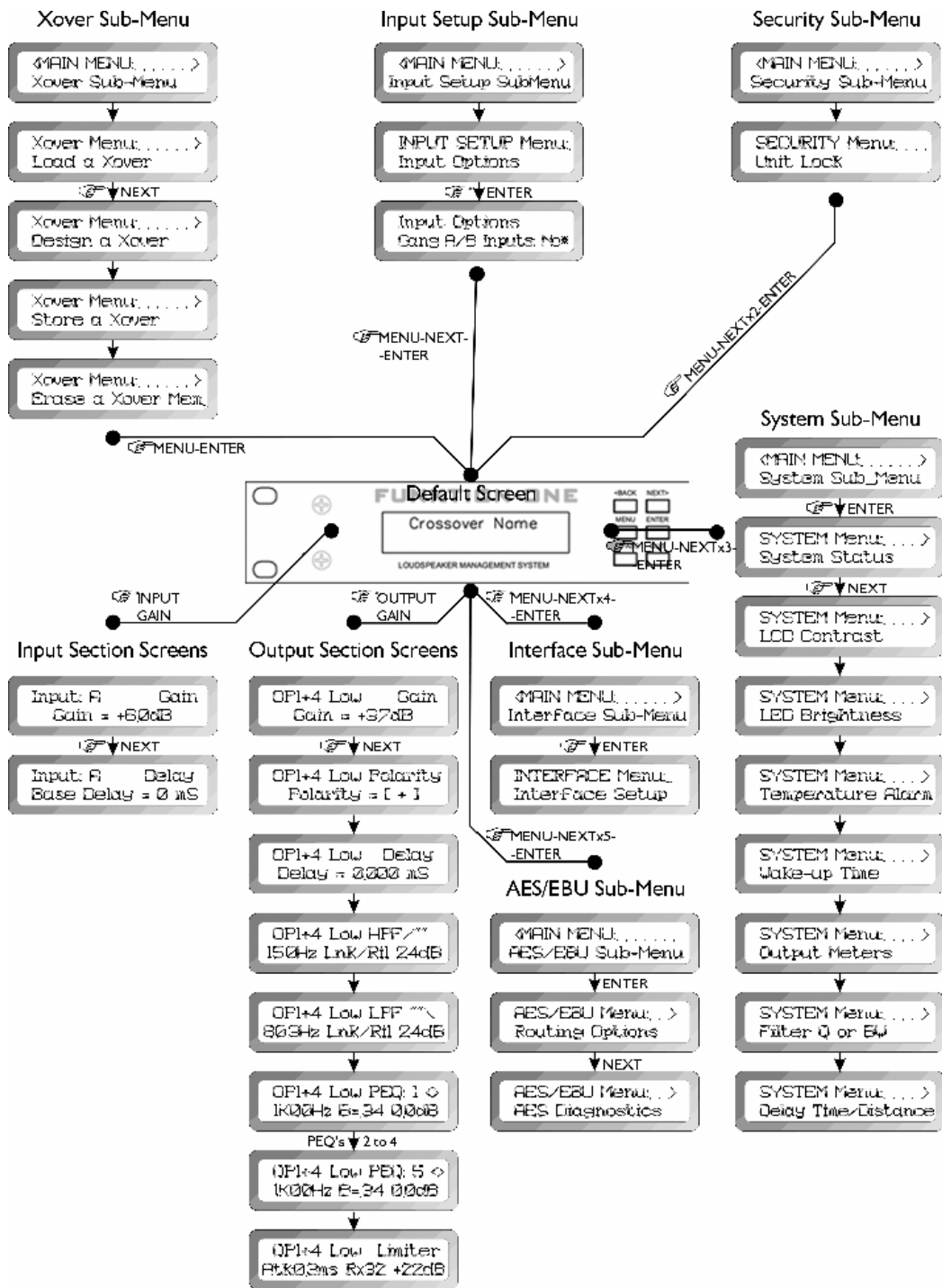

Audio Function Screens

Gain Screen

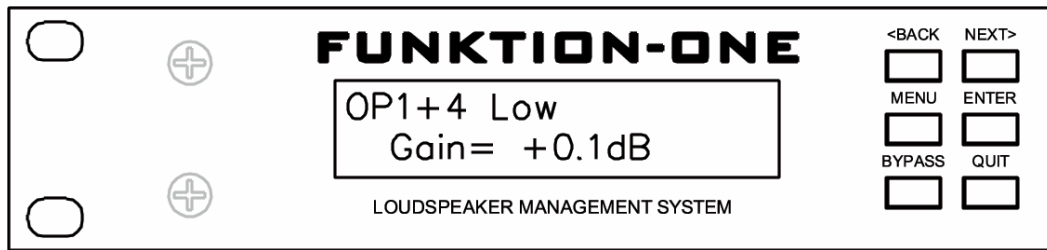

To adjust the gain:

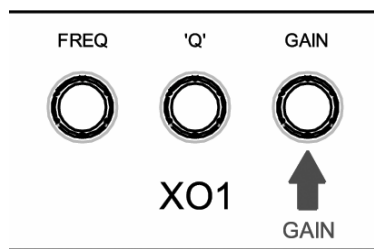

Use the 'GAIN' control.

Each input and output has an individual gain screen. The inputs have a range of +6dB to -40dB, adjustable in 0.1dB steps and the outputs have a range of +15dB to -40dB, again adjustable in 0.1dB steps.



For further details on this topic, see the section entitled "Operating Level" on page 31.

Polarity Screen

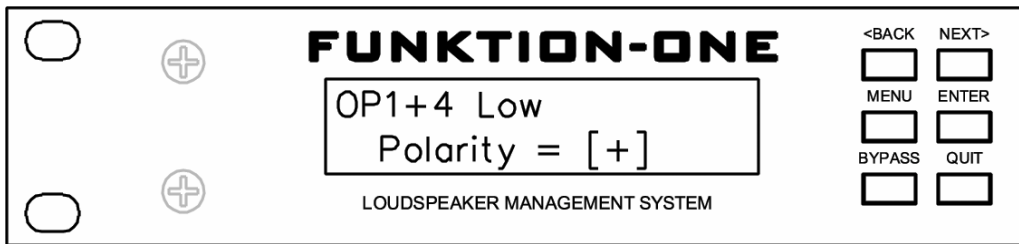

To adjust the polarity:

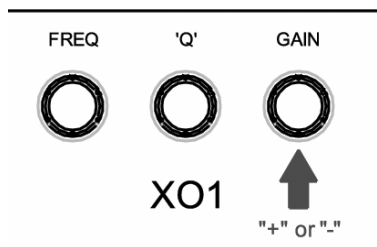

Use the 'GAIN' control to switch between + and -.

Each output has an independent polarity screen. This gives the flexibility to reverse (flip by 180°) the phase of individual outputs.



Note: When the outputs are ganged, the polarity screens remain individual.

Delay Screen

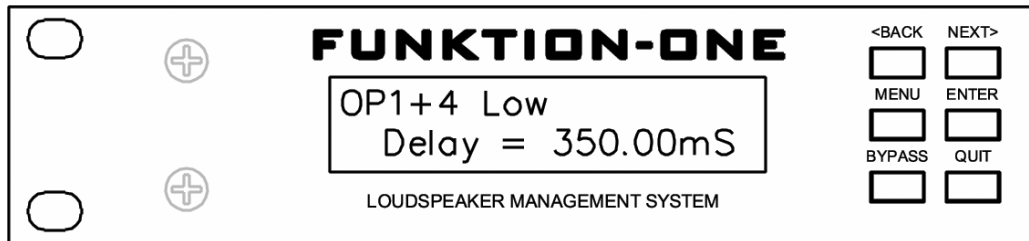

To adjust delay settings:



Use the 'FREQ' control for coarse control. (1mS steps)

Use the 'Q' control for fine control. (2.6µS steps)

Each input and output has an independent delay time control. Input delay (base delay) is adjustable in 1mS steps. Output delay is adjustable in 2.6µS steps or in 1mS steps giving complete control over driver time alignment.

The combination of input (base) delay and output delay can be a maximum of 650mS. So, for example, setting a base delay of 500mS on input A will only leave 150mS for any outputs that are sourced from input A. The exception to this rule is for any 'aux' outputs (available in 4 and 5 way crossover modes). Choosing the source as a mono sum (Inputs A + B) will allow 650mS of output delay, regardless of the input delay settings.



For further details on this topic, see the section entitled "Time Alignment" on page 32.

High and Low Pass Filter Screens



To adjust HPF/LPF settings:

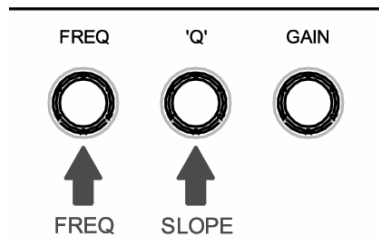

Use the 'FREQ' control for the frequency.
Use the 'Q' control for the slope.

Each output has an independent high pass filter and an independent low pass filter. Both filters have a range of selectable slopes, which are Bessel 12dB, 18dB and 24dB, Butterworth 12dB, 18dB and 24dB, and Linkwitz-Riley 24dB. Highpass filters have a range of < 10Hz (through) to 16kHz and Lowpass filters have a range of 22kHz (through) to 39Hz in 1/36 octave steps. HPFs and LPFs can be set asymmetrically.



For further details on this topic, see the section entitled "Crossover Filter Slopes" on page 32.

Parametric Equaliser Screen

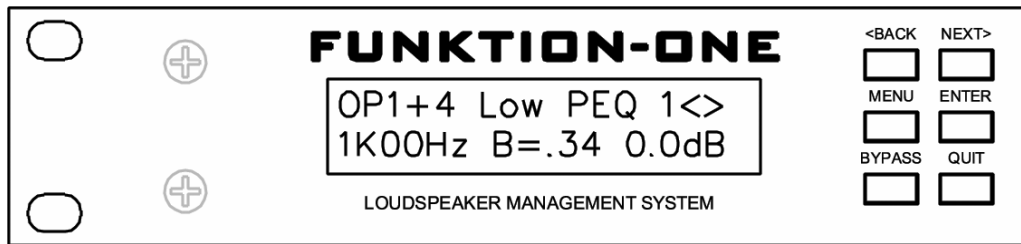

To adjust parametric settings:

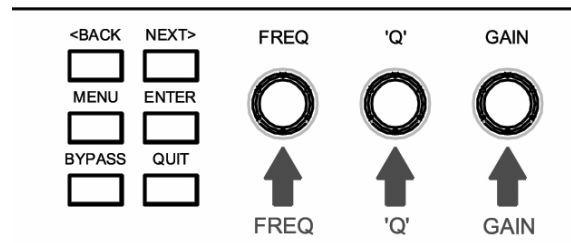

Use the 'FREQ' control for the frequency.
Use the 'Q' control for the Q.
Use the 'GAIN' control for the gain.

Each parametric section can be positioned at a frequency from 20Hz to 20kHz and features a wide range of 'Q's to produce response curves ranging from broad to notch. The gain control ranges from +15dB to -30dB in 0.1dB steps. Frequency steps are 1/36 octave resolution for precise control. Since all filtering is achieved in DSP all settings are re-settable with absolute accuracy and in ganged mode parameters track identically. Very narrow band notch filters (maximum 'Q' of 128) can be achieved and unlike analogue filters these tight 'Q' filters are entirely stable. The maximum notch depth is -30dB.

Parametric filters are carefully implemented using Double Precision processing. This method is costly in terms of processing power but yields substantial benefits in terms of the XO1's exceptional noise performance and greatly improved low frequency stability.

(Note: To show parametric filters in bandwidth (BW) rather than 'Q', go into the 'System sub-menu', select 'filter Q or BW', select BW.)

To switch a filter from parametric mode to shelving mode, set the gain of the filter to 0dB and then turn the 'Q' control anti-clockwise until 'HiSHF' or 'LoSHF' is displayed. Now set the frequency and gain as required. To set the filter back to a parametric section, just ensure that the gain is at 0dB, otherwise the 'Q' control will have no effect.

Limiter Screen



To adjust limiter settings:

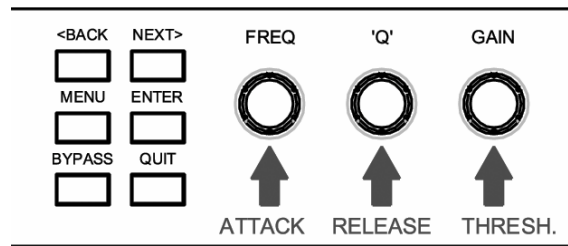

Use the 'FREQ' control to adjust the attack time.

Use the 'Q' control for the release time.

Use the 'GAIN' control for the limiter threshold.

Each output has an independent high performance limiter.

All limiters have an attack range of 0.3mS to 90mS, release times are 2, 4, 8, 16 and 32 times the attack time and thresholds range from +22dB to -10dB in 1dB steps.

If the automatic limiter time constant option is in use, all limiter screens will say 'automatic' and the time constants will be set from the high pass filter frequency. A table of dB to Vrms, in case the amplifier sensitivity is given in Volts rather than dB, is in appendix I.

The output meters are linked to the time constants of the limiters so true output metering is achieved.



For further details on this topic, see the section entitled "Output Limiters" on page 33.

Menu Selection

The following menu selections are available:

Xover Sub-menu:

- Load a Xover – loads a pre-defined crossover.
- Design a Xover – starts the set-up wizard for designing a new crossover.
- Store a Xover – stores all output settings as a defined crossover.
- Erase a Xover Mem. – erase an individual crossover memory.

Input Set-up Sub-menu:

- Gang Inputs - Allows ganging of inputs for stereo operation.
- All PEQ's Flat – Sets all input parametric sections back to default values.

Security Sub-menu:

- Locks the unit with a 4 digit code, at one of many user definable levels.

DO NOT ENTER THIS MENU BEFORE HAVING THOROUGHLY UNDERSTOOD THE WAY THE LOCK-OUT WORKS, AS DESCRIBED ON PAGE 26.

System Sub-menu:

- System Status – displays unit info, such as version & internal temperature.
- LCD Contrast – adjusts the contrast of the LCD screen.
- LED Brightness – adjusts the brightness of all indicator LEDs.
- Temperature Alarm – sets a temperature warning threshold in °C.
- Wake-up Time – sets time take for unit to pass audio after power-up.
- Output Meters – selects whether meters are monitoring pre or post mute.
- Filter Q or BW – selects display type for parametric filter screens.
- Delay Time/Distance – select units to display delays in (mS/m/ft)

Interface Sub-menu:

- Interface Setup – enable/disable interface and set baud rate.

AES/EBU Sub-menu:

- Routing Options – select various routing options.
- AES Diagnostics – shows complete status of AES signal.
(Only available if the AES/EBU option is fitted.)

Input Setup Sub-menu

There is one option in this menu:

Gang Inputs

Gangs A and B inputs so that precise adjustments can be made to both inputs simultaneously, the LCD will show A+B. All adjustments are now absolute and any adjusted parameters on both channels will become identical . If it is necessary to introduce an off-set on any parameter, un-gang the inputs, and adjust. If re-ganged, channel B will jump to channel A's setting.

X-over Sub-Menu

Load a Xover

Loads a stored crossover from the selection available. Enter accepts the selected name and loads immediately.

Design a Xover

Opens a wizard to design a crossover. Options include format type, ganging of outputs, routing and automatic limiter time constants. The table below outlines which options are available dependant on what type of crossover is chosen for the design.

2 x 2 Way	2 x 3 Way	4 Way	5 Way	6 Way
		Out 5 Source:A/A+B		
Gang Outputs:Yes/N o	Gang Outputs:Yes/N o	Out 6 Source:A/A+B	Out 6 Source:A/A+B	
Auto Limit TC:Yes/No	Auto Limit TC:Yes/No	Auto Limit TC:Yes/No	Auto Limit TC:Yes/No	Auto Limit TC:Yes/No

Store a Xover

Stores a X-over (all output settings) to one of 9 locations. Crossovers can be named, using the same method as memories, with up to 16 characters which appear in the default screen on the top line of the display.

Erase a Xover Mem

Permits clearing (erasing) of individual crossover memories from the unit. Note that, once erased, the memory name disappears from the list of recallable locations. If the crossover memory is currently in use, it's name will remain on the default screen, and the current settings will not be changed.

Security Sub-Menu

After selecting the 'Security Sub-Menu' and pressing ENTER, select one of the lock types, after choosing the most appropriate one for your application. As ever, ENTER will confirm your selection.

User Specific

Upon pressing ENTER to select this type of lock, each parameter group is presented in turn. Choose the type of lock (as above) using the FREQ encoder, and press ENTER to confirm each parameter. After the last parameter, the unit requests a password. The description of this operation is given at the end of this section.

This option allows the user to specify, for each type of parameter, whether it is to be completely accessible ('No Lock'), viewable but not adjustable ('Control'), or effectively unavailable ('Display'). The ability to operate mutes, store or recall memories, or even access the menus may also be locked.

Xover Only

All input parameters are available, but only the gain trim is available on the outputs, effectively locking all the crossover settings. All mutes remain active.

Xover + Trim

All input parameters available, but no output parameters – the crossover sections are completely locked. All mutes remain active.

Xover + Trim + Mute

As for 'Xover + Trim' but additionally, output mutes are locked. Input mutes remain active.

Changes Only

All parameters may be viewed, but none may be adjusted. This applies to both inputs and outputs. All mutes remain active.

Changes + View

No parameters are accessible – in effect the SELECT keys do nothing. All mutes remain active.

Changes + Mutes

All parameters may be viewed, but none may be adjusted. This applies to both inputs and outputs. All mutes are also locked.

EVERYTHING

No parameters are accessible – in effect the SELECT and MUTE keys do nothing.

Entering the Password to Complete the Locking Operation

After selection of the lock type from the list above, a four-digit security code will be asked for. This can be entered by using the 'FREQ' control to select a character, and the 'BACK' and 'NEXT' keys to move to the next character.

Alternatively, the 'SELECT' keys can be used to enter a code by pressing any combination of the eight buttons. Each 'SELECT' key represents its channel labelling, so any combination of A, B, 1, 2, 3, 4, 5 and 6 can be used as a code, as shown below.

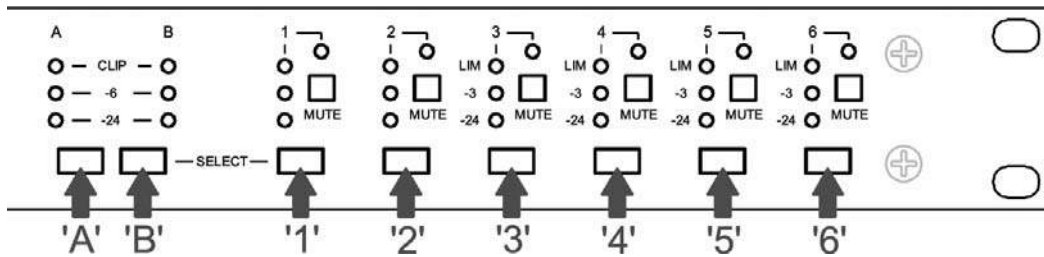

IMPORTANT - Please note your code! If the security code number is forgotten contact your local sales office.

System Sub-Menu

System Status

Displays unit information including software version and temperature.

Curr. Temp. = current temperature in degrees Celsius.

Max1. Temp. = maximum temperature this session.

Max2. Temp. = maximum temperature ever reached.

LCD Contrast

Adjusts the LCD contrast from 0 to 100.

LED Brightness

Adjusts the LED brightness from 1 to 15.

Temperature Alarm

Sets a temperature warning between 20 and 80°C. The default screen will flash 'ALARM. Temp = $n^{\circ}\text{C}$ ' when the specified temperature is reached. (N.B. the warning does not affect the units' performance in any respect.)

Wake-up Time

Sets how the unit starts up with one of the following options.

0 to 60 seconds: Waits the specified time before unit wakes up.

Mute hold: Turns on and holds all output mutes when turned on.

(N.B. Wake-up is a slow ramp in level for about 5 seconds.)

Output Meters

Selects whether the output meters are pre or post mute. If the meters are set to read pre-mute, they will still show the level, even if the channel has been muted.

Filter Q or BW

Selects whether 'Q' or Bandwidth is displayed in the parametric screens.

Delay Time/Distance

Selects whether delay is displayed in milliseconds, metres, or feet.

Interface Sub-Menu

Interface Setup

If the interface is enabled, the option will become available to select the baud rate. This must be set to match that on the PC to be used for the program update. Typically, the set-up would be as below.

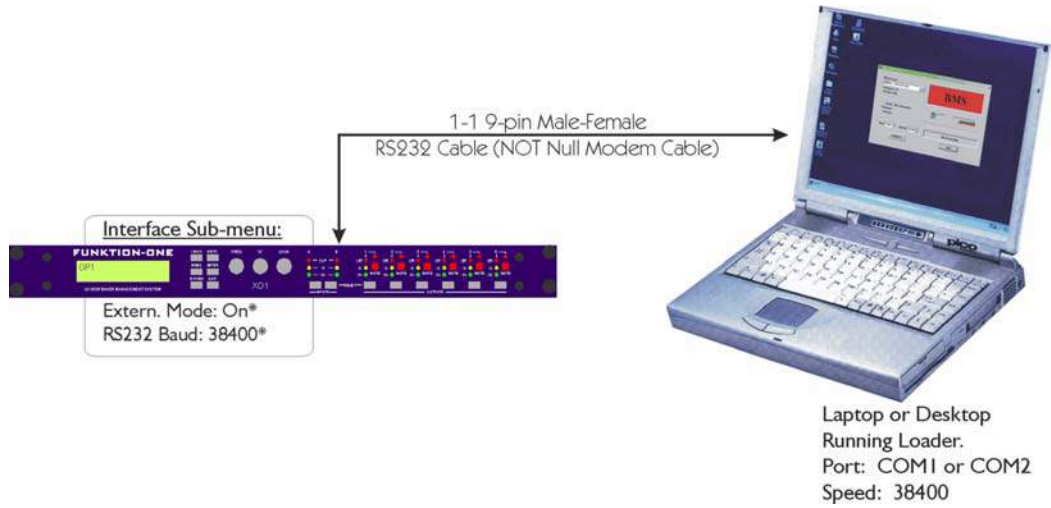

AES / EBU Sub-Menu

Connection of AES/EBU signals is via the existing rear panel XLR connectors. With the AES/EBU option fitted, AES Receive and Diagnostic modes are provided.

Routing Options

Selects the input source – either analogue or digital, and similarly the output source, again either analogue or digital.

AES Diagnostics

Reports validity flag, clock speed and errors present in the incoming AES digital signal.

AES / EBU Connections

The AES/EBU digital signal is a stereo data stream, and so only one input XLR and three output XLRs are used for the digital interface.

The connections are as follows:

- Input A - Analogue Input at all times
- Input B - Switchable between digital (stereo) input and analogue input

- Output 1 - Switchable between digital out (for channels 1 & 2) and analogue out 1
- Output 2 - Switchable between digital out (for channels 3 & 4) and analogue out 2
- Output 3 - Switchable between digital out (for channels 5 & 6) and analogue out 3

- Output 4 - Analogue output 4 only
- Output 5 - Analogue output 5 only
- Output 6 - Analogue output 6 only

Operating Notes

Operating Level

With any audio signal processing equipment it is necessary to ensure adequate signal level is used through the device, to avoid sacrificing noise performance. It is suggested that the operating level chosen should give adequate level to just light the -12dB LED on the headroom meter with maximum program level being used. Since the meter is deliberately set to show clipping 3dB early, this still provides 9dB of headroom before clipping occurs. With equalisation in use it may be necessary to further reduce the input level, as gain within the unit may cause digital clipping, indicated by the top red LED's lighting independently of the rest of the meter.

It should be noted that the figure quoted for the maximum input level options is the clipping point for that option (not a safe operating level). Always ensure that this clipping point is no lower than that for the following equipment in the signal chain, and allow extra margin if equalisation sections are boosted.

Grounding

The Screen (shield) pins on all audio connectors are normally connected directly to the ground pin of the IEC mains inlet. The chassis is also directly connected to this pin. Never operate this unit without the mains safety ground connected. Signal ground (0V) is in turn connected to the chassis ground.

To avoid ground loops, cable shields should be connected to ground at one end only. The normal convention is that the shield is only connected at the output XLR. Provision is also made for separately isolating each input and output shield pin permanently within the XO1 by breaking the appropriate PCB track, where marked with a box and an arrow next to each XLR connector using a small drill bit or cutter. See the following diagram for details.

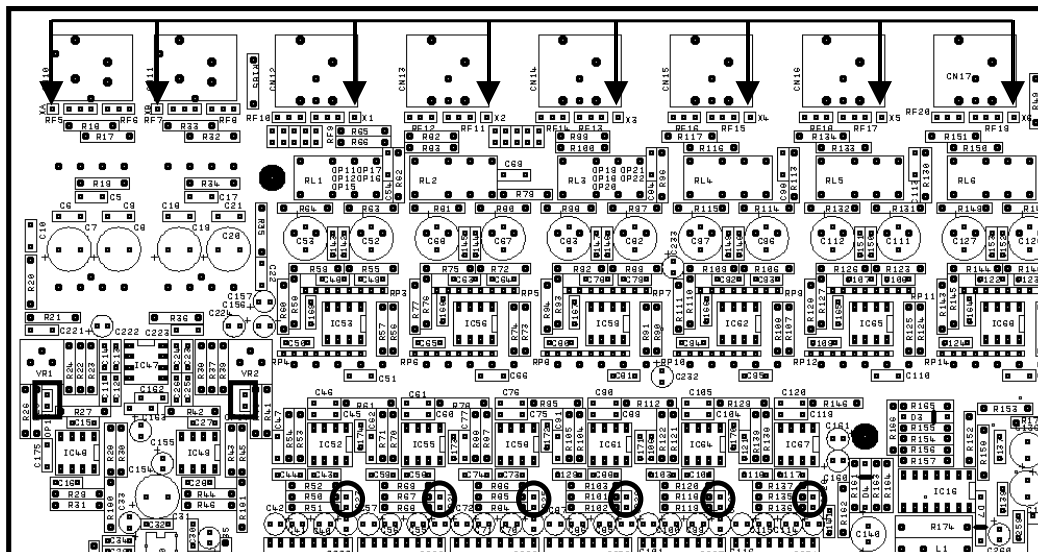

XLR pin 1 Isolation points (arrowed) and 10dB pads (circled)

Crossover Filter Slopes

Please consult the block diagrams on page 11 for details of the various configurations available. All crossover modes feature adjustable crossover frequencies with a choice of slopes, 5 bands of driver compensation E.Q. per output and delay time plus limiters for each output. A powerful 8 band parametric equaliser is also provided on each input for room equalisation. Phase reverse is provided for each output.

A choice of Bessel or Butterworth slopes at 12/18/24dB per octave and Linkwitz-Riley at 24dB per octave are provided. Since Low and High pass functions are separately adjusted, asymmetric slopes are easily achieved, if required. It should also be noted that the turnover frequency displayed on the XO1 is the -3dB point for all slopes except 24dB Linkwitz-Riley where the -6dB point is shown. If the -6dB point is to be used for the Bessel or Butterworth filter, take the required crossover frequency, multiply this by the appropriate factor from the following table and then select the closest available frequency on the XO1's display.

Filter Type	High pass factors	Low pass factors
Bessel 12dB/Oct.	1.45	0.69
Butterworth 12dB/Oct.	1.31	0.76
Bessel 18dB/Oct.	1.37	0.73
Butterworth 18dB/Oct.	1.19	0.84
Bessel 24dB/Oct.	1.35	0.74
Butterworth 24dB/Oct.	1.15	0.87

Please note that unlike conventional analogue crossovers, crossover points and slopes are set with absolute accuracy since component tolerance problems do not occur.

Time Alignment

A further advantage of the XO1 over conventional products is the provision of an independently adjustable delay section for each output. This allows the true arrival time from multiple drivers to be precisely aligned rather than relying on the compromise 'phase adjust' approach. Delay time is adjustable in 2.6µS steps (1mm). Please see page 19 for details of how to adjust the delay times.

To convert from units of time (i.e. milliseconds) to units of distance use the following formula:

$$1 \text{ millisecond} = 343\text{mm (1.126ft)} @ 20^\circ\text{C (68}^\circ\text{F)}$$

To calculate time delay for a known distance, use:

$$\text{Time delay} = \text{Distance in meters}$$

$$20.06 \times \sqrt{273 + ^\circ\text{C}}$$

where °C is the temperature in °C.

To simplify this equation at 20°C.

$$\text{Delay time in milliseconds} =$$

$$(\text{Distance in meters} \times 2.192) \text{ or } (\text{Distance in feet} \times 0.955)$$

Note: Centigrade = (Fahrenheit - 32) x 0.5555.

Output Limiters

High performance digital limiters are provided for each output with control over attack time, release time and threshold level parameters - see page 22 for details. This level of control allows the user to balance the required subjective quality of the limiter against the driver protection requirements. It does also mean that an incorrectly set limiter may sound awful! In particular, as with all limiters, using too fast an attack or release time will result in excessive low frequency distortion. In the 'Design a Xover' sub-menu there is an option for automatic limiter time constants. In this mode the time constants will be automatically set from the Highpass filter frequency according to the table below.

The time constants are set by the high pass filter frequency for that channel.

High Pass Filter	Auto Attack Time	Release Time
<10Hz – 31Hz	45mS	x16 (720mS)
31Hz – 63Hz	16mS	x16 (256mS)
63Hz – 125Hz	8mS	x16 (128mS)
125Hz – 250Hz	4mS	x16 (64mS)
250Hz – 500Hz	2mS	x16 (32mS)
500Hz - 1kHz	1mS	x16 (16mS)
1kHz – 2kHz	0.5mS	x16 (8mS)
2kHz – 22kHz	0.3mS	x16 (4mS)

Setting Accurate Limiter Thresholds

The limiters built into the XO1 are intended to be used for for loudspeaker driver protection, as opposed to amplifier protection. All modern professional power amplifiers designed for live sound use have their own limiters which are tailored to protecting the amplifier from clipping.

The following section describes how to set up the XO1's limiters to provide exceptional protection against driver overheating, and cone over-exursion.

Most speaker systems are given a power rating in Watts RMS. This is the maximum continuous power that the system will handle and often appears very conservative. In reality, as music program is far from continuous in nature, the peak power of the system is much higher – up to ten times the continuous figure. Any limiter, which is to protect the driver from damage, must be able to fulfil the following tasks.

Have an attack time which is calculated to allow transients through but keep the RMS level below the speaker manufacturers specification;

Have a release time which is sufficiently long to avoid the limiter itself modulating the program ;

Be intelligent enough to adjust the envelope of the limiter according to the frequency content of the program material.

The XO1's limiters are capable of performing all these tasks. The only parameter which the user must set manually is the threshold, and it is crucial that this is done correctly. Consider the table below.

dB	Ratio	Vrms	Pwr 8 Ω	Pwr 4 Ω	Pwr 2 Ω
45	177.83	137.74	2371.71	4743.42	9486.83
44	158.49	122.77	1883.91	3767.83	7535.66
43	141.25	109.41	1496.45	2992.89	5985.79
42	125.89	97.52	1188.67	2377.34	4754.68
41	112.20	86.91	944.19	1888.39	3776.78
40	100.00	77.46	750.00	1500.00	3000.00
39	89.13	69.04	595.75	1191.49	2382.98
38	79.43	61.53	473.22	946.44	1892.87
37	70.79	54.84	375.89	751.78	1503.56
36	63.10	48.87	298.58	597.16	1194.32
35	56.23	43.56	237.17	474.34	948.68
34	50.12	38.82	188.39	376.78	753.57
33	44.67	34.60	149.64	299.29	598.58
32	39.81	30.84	118.87	237.73	475.47
31	35.48	27.48	94.42	188.84	377.68
30	31.62	24.49	75.00	150.00	300.00

Using this table it is a straightforward procedure to work out the required setting of the limiter thresholds for the system. Follow the steps described overleaf.

First, check the RMS power rating of the speaker system, and its impedance.
Look up this value in the table above, using the closest value below the rated power of the speaker system. Note the corresponding 'dB' value.
Check the gain of your amplifier, which needs to be in 'dB'.
Subtract this gain figure from the dB value obtained from the table to find the required absolute setting for the limiter thresholds.

Note that, for safety, always set the limiter threshold 1 or 2 dB below the maximum allowable worked out using the above method.



ALWAYS REFER TO YOUR SPEAKER MANUFACTURER FOR
LIMITER SETTINGS.

Specifications

Inputs: 2 electronically balanced ◆
Impedance: > 10k ohms.
CMRR : >65dB 50Hz - 10kHz.

Outputs: 6 electronically balanced ◆
Source Imp: < 60ohms
Min. Load: 600ohm
Max. Level: +20dBm into 600 ohm

Frequency Resp.: ± 1/2dB 20Hz-20kHz
Dyn Range: > 110dB 20Hz-20k unwt'd
Distortion: < .02% @ 1kHz, +18dBm
Maximum Delay: 650 mS
Min Step Size: 2.6 μS
Input Gain: +6dB to -40dB in 0.1dB steps
Output Gain: +15dB to -40dB in 0.1dB steps and mute

Parametric Equalisation
5 Sections per Output
Filter Gain: +15dB to -30dB in 0.1dB steps.
Freq. Range: 20Hz - 20kHz, 1/36 octave steps. (368 positions)
Filter Q / BW: 0.4 to 128 / 2.5 to 0.008 (Sections switched to shelving response)
Low frequency: 20Hz - 1kHz
High frequency: 1kHz - 20kHz
Shelf gains: ±15dB in 0.1dB steps.

High and Lowpass Filters
Filters: 1 of each per output.
Freq. Range HPF: 10Hz - 16kHz
1/36 octave steps.
Freq. Range LPF: 35Hz - 22kHz
1/36 octave steps.
Responses:
Bessel/Butterworth 12-18-24dB/Oct.
Linkwitz-Riley 24dB/Oct.

Limiters
Threshold: +22dBu to -10dBu
Attack time: 0.3 to 90 milliseconds
Release time: 2/4/8/16/32 x Attack time

Display: 2x20 character backlit LCD

Input meter: 2 x 3 point
Output meter: 6 x 3 point

Connectors
Inputs: 3 pin female XLR
Outputs: 3 pin male XLR.
External: 9 pin DEE connector (RS232)
Power: 3 pin IEC

Power: 60 to 250V ±15% @ 50/60Hz.

Consumption: < 20 watts.

Weight: 3.5kg. Net (4.8kg. Shipping)

Size: 1.75"(1U) x 19" x 11.8"
(44 x 482 x 300mm) excluding connectors.

Options ◆ = Transformers available.

Optional Interfaces AES/EBU Digital Input/Output

Due to continuing product improvement the above specifications are subject to change.

Warranty

This product is warranted against defects in components and workmanship only, for a period of one year from the date of shipment to the end user. During the warranty period, XTA will, at its discretion, either repair or replace products which prove to be defective, provided that the product is returned, shipping prepaid, to an authorised XTA service facility.

Defects caused by unauthorised modifications, misuse, negligence, act of God or accident, or any use of this product that is not in accordance with the instructions provided by XTA, are not covered by this warranty.

This warranty is exclusive and no other warranty is expressed or implied. XTA is not liable for consequential damages.

FUNKTION-ONE

Options and Accessories

Part Description
XOI Transformer balanced inputs (factory fitted only)
XOI Transformer balanced outputs (factory fitted only)
AES/EBU Digital inputs/outputs (factory fitted only)
9 pin 'D' type to 9 pin 'D' type cable. (1m)

Appendices

Appendix 1: Limiter threshold in dB to Vrms lookup table.

dB	Vrms	dB	Vrms
+22	9.75	+5	1.38
+21	8.69	+4	1.23
+20	7.75	+3	1.09
+19	6.90	+2	0.98
+18	6.15	+1	0.87
+17	5.48	0	0.77
+16	4.89	-1	0.69
+15	4.36	-2	0.62
+14	3.88	-3	0.55
+13	3.46	-4	0.49
+12	3.08	-5	0.44
+11	2.75	-6	0.39
+10	2.45	-7	0.35
+9	2.18	-8	0.31
+8	1.95	-9	0.27
+7	1.73	-10	0.24
+6	1.55		

Calculation:

$$V_{rms} = 0.7746 \times 10^{\wedge} (dBu + 20)$$

Appendix 2: Default X-over settings and names for all formats.

X-over	Output 1	Output 2	Output 3	Output 4	Output 5	Output 6
2x2 way+Ms	Low	High	Low	High	Msub	Aux
	120Hz – 1k82Hz 1k82Hz – 22kHz 120Hz – 1k82Hz 1k82Hz – 22kHz 24.8Hz – 120Hz <10Hz – 22kHz					
2 x 3 way	Low	Mid	High	Low	Mid	High
	22.1Hz – 120Hz 120Hz – 1k82Hz 1k82Hz – 22kHz 22.1Hz – 120Hz 120Hz – 1k82Hz 1k82Hz – 22kHz					
4 way + 2	Low	LoMid	HiMid	High	Aux	Aux
	15Hz – 149Hz 149Hz – 1k31Hz 1k31Hz – 8kHz 8kHz – 22kHz 20.1Hz – 22kHz 20.1Hz – 22kHz					
5 way + 1	Sub	Low	LoMid	HiMid	High	Aux
	15Hz – 80.3Hz 80.3Hz – 180Hz 180Hz – 1k31Hz 1k31Hz – 8kHz 8kHz – 22kHz 20.1Hz – 22kHz					
6 way	LoSub	Sub	Low	LoMid	HiMid	High
	15Hz – 80.3Hz 80.3Hz – 149Hz 149Hz – 1kHz 1kHz – 4kHz 4kHz – 10k1Hz 10k1Hz – 22kHz					

Note: All filters set to 24dB Linkwitz-Riley.

Appendix 3: Equalisation Curves

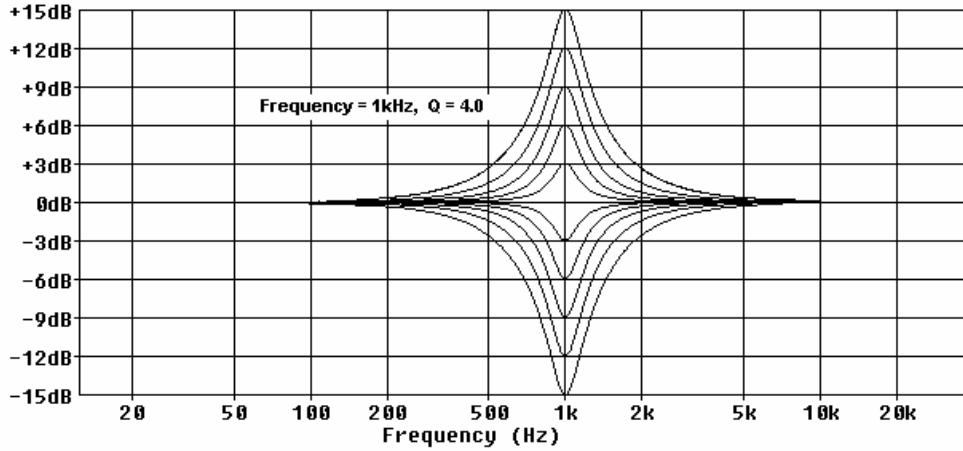

Parametric Filter Gain Curves

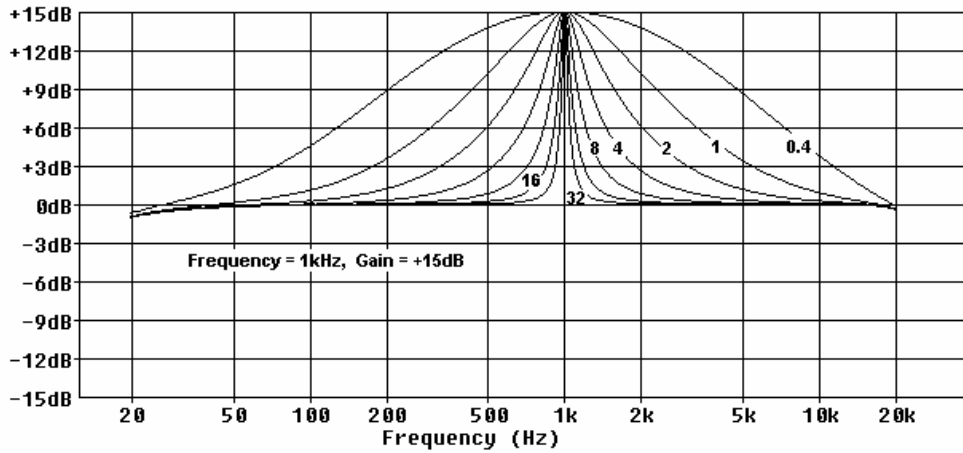

Parametric Filter 'Q' Curves

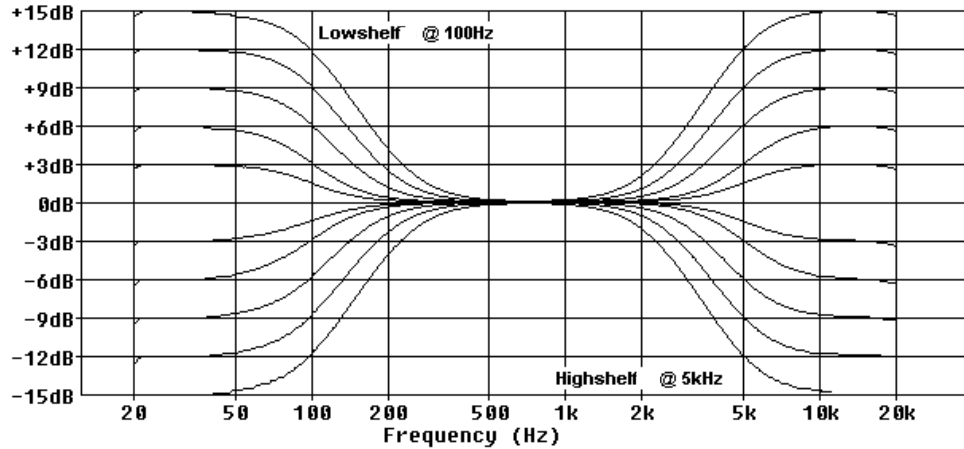

Parametric Filter High and Low Shelving Responses

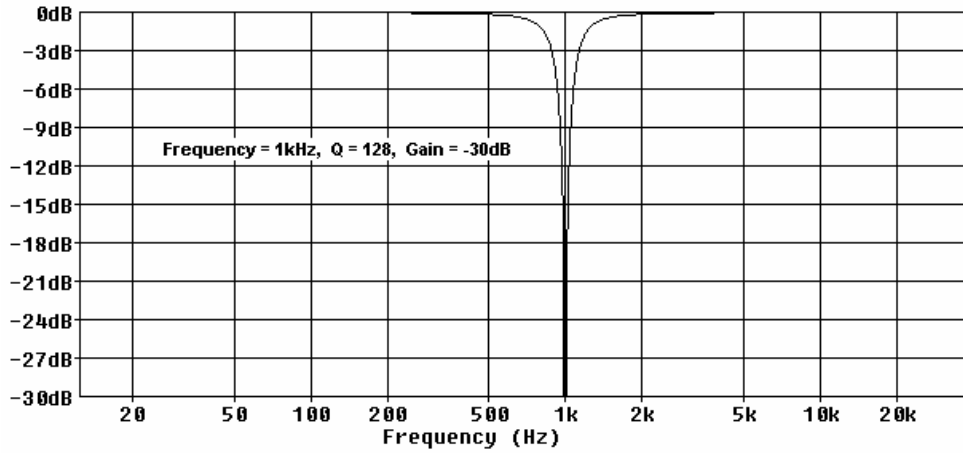

Parametric Filter High 'Q' – Notch Filter Response

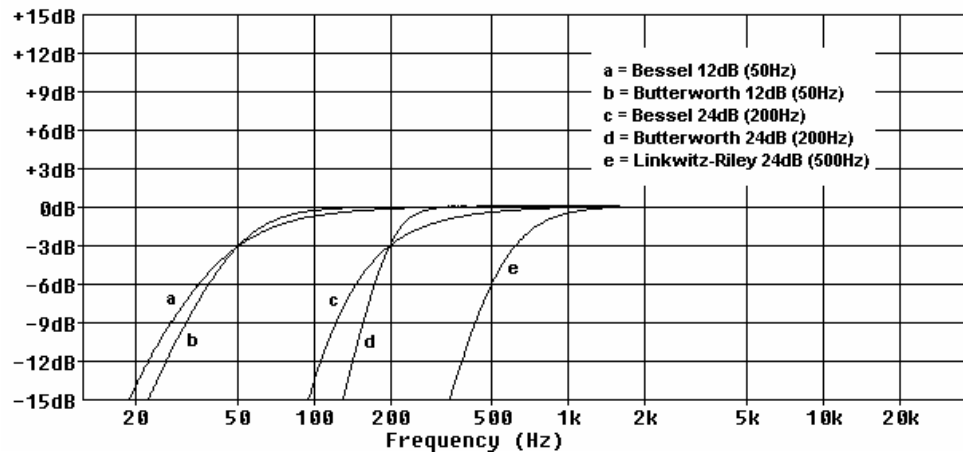

High Pass Filter Response Curves

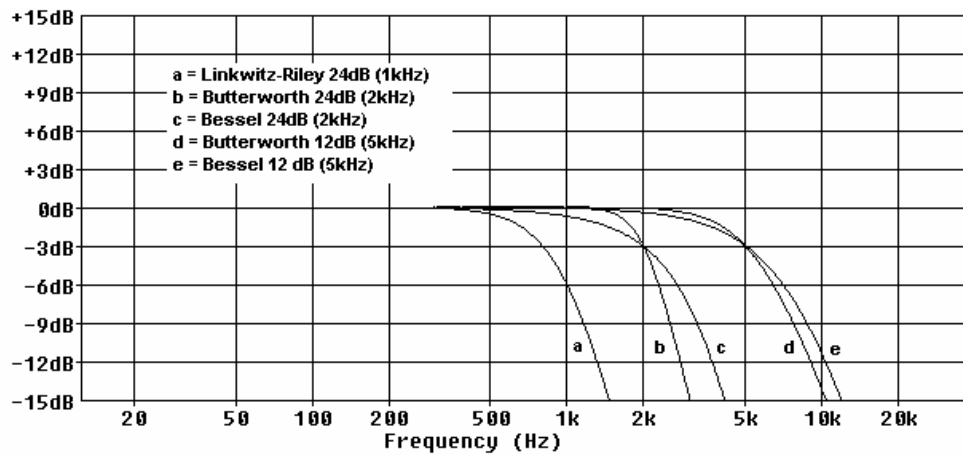

Low Pass Filter Response Curves